

Subject Code: R13109/R13

Set No - 1

I B.Tech I Semester Regular/Supple. Examinations Nov./Dec. - 2015

ENGINEERING DRAWING

(Common to ECE, EIE, Bio-Tech, E Com.E, Agri.E)

Time: 3 hours

Max. Marks: 70

Question Paper Consists of **Part-A** and **Part-B**
 Answering the question in **Part-A** is Compulsory,
 Three Questions should be answered from **Part-B**

PART-A

1. (a) Draw the isometric view of Fig.1.

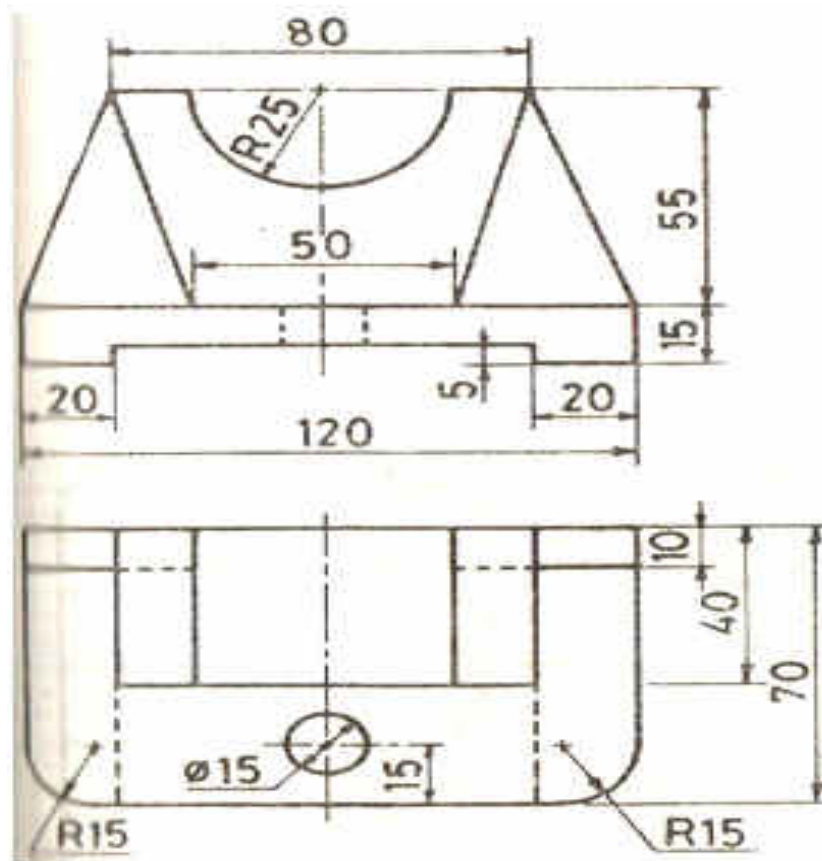

Fig.1

(b) Draw the projections of a rhombus having diagonals 65mm and 30mm long. The smaller diagonal is parallel to both HP and VP while the other is inclined at 30° to HP. [12+10]

PART-B

2. (a) The distance between two fixed points is equal to 75mm. A point P moves such that the sum of its distances from the two fixed points is always a constant and is equal to 90mm. Draw the locus of P and determine the minor axis.



Subject Code: R13109/R13

Set No - 1

2. (b) Construct a diagonal scale of RF=1/32 showing yards, feet and inches and measure up to 4 yards. [8+8]
3. (a) Draw the projections of a line CD 50mm long, parallel to HP and inclined to VP. The end C is 10mm in front of VP and D is 30mm in front of VP. The line is 15mm above HP. [8+8]
 (b) A point P is 15mm above the HP and 20mm in front of the VP. Another point Q is 25mm behind the VP and 40mm below the HP. Draw projections of P and Q keeping the distance between their projectors equal to 90mm. Draw straight lines joining
 (i) their top views and (ii) their front views. [8+8]
4. The top view of a 75mm long line AB measures 65mm, while the length of its front view is 50mm. Its one end A is in the HP and 12mm in front of the VP. Draw the projections of AB and determine its inclinations with the HP and the VP. [16]
5. Draw the projections of a pentagonal sheet of 26mm side, having its surface inclined at 30° to VP. Its one side is parallel to VP and inclined at 45° to HP. [16]
6. Draw the projections of a cylinder 75 mm diameter and 100mm long. Lying on the ground with its axis inclined at 30° to the VP and parallel to the ground. [16]
7. Draw Fig.2 (a) Front View (b) Top View (c) Side View [16]

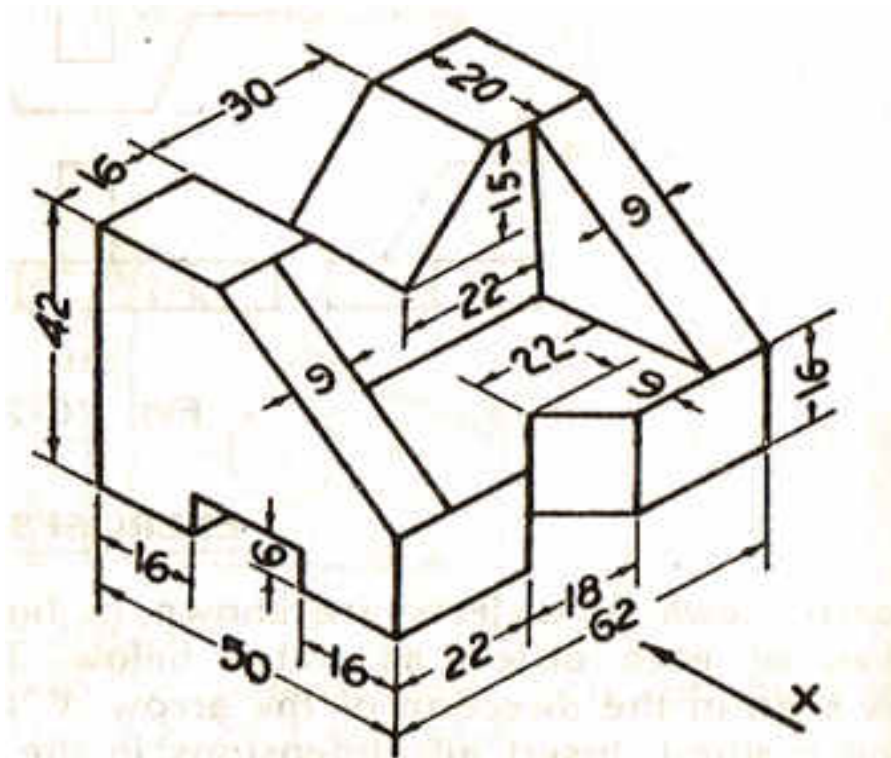

Fig.2



Subject Code: R13109/R13

Set No - 2

I B.Tech I Semester Regular/Supple. Examinations Nov./Dec. - 2015

ENGINEERING DRAWING

(Common to ECE, EIE, Bio-Tech, E Com.E, Agri.E)

Time: 3 hours

Max. Marks: 70

Question Paper Consists of **Part-A** and **Part-B**
 Answering the question in **Part-A** is Compulsory,
 Three Questions should be answered from **Part-B**

PART-A

1. (a) Draw Fig.1 (i) Front View (ii) Top View (iii) Side View

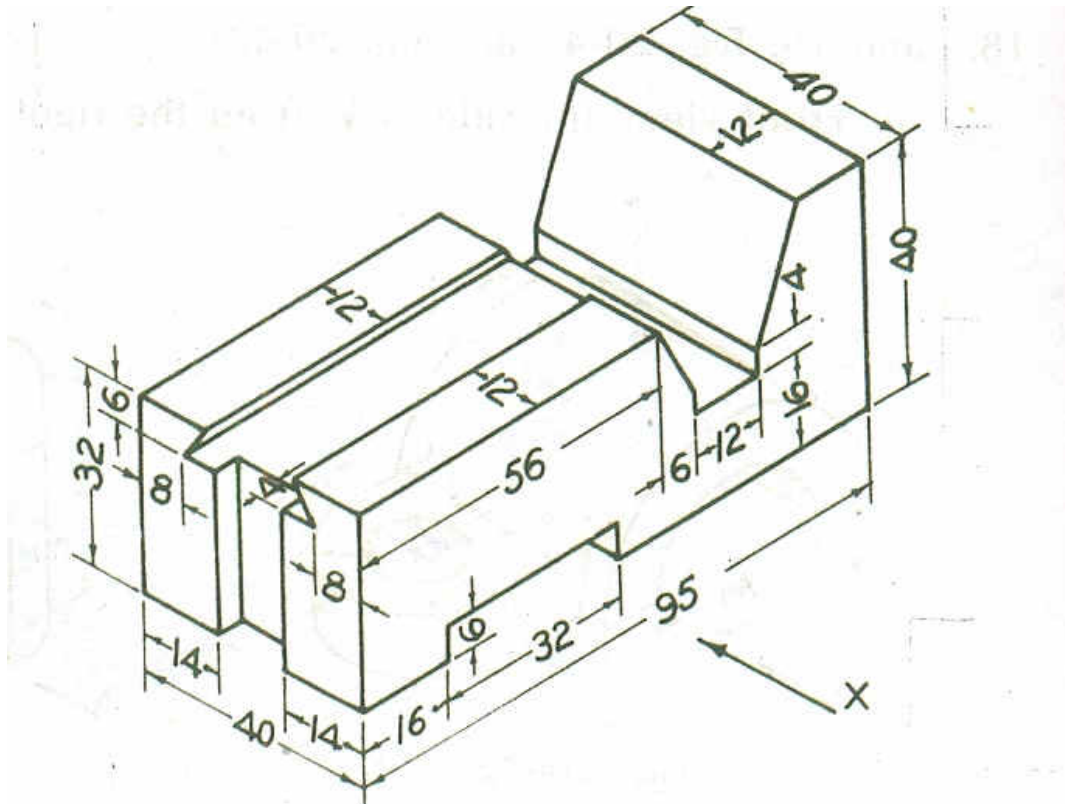

Fig.1

- (b) An isosceles triangular lamina has base 40mm long and altitude 56mm. It is so placed on VP such that in the front view it is seen as an equilateral triangle of 40mm sides with the side that is contained in VP is inclined at 45° to HP. Draw its top and front views. Also, find the inclination of the lamina to VP.

[12+10]

PART-B

2. (a) Draw an octagon given the length of side 25mm.
 (b) A car is running at a speed of 50km/hour. Construct a diagonal scale to show 1 km by 3cm and to measure up to 6km. Mark also on the scale the distance covered by the car in 5 minutes 28 seconds.

[8+8]



Subject Code: R13109/R13

Set No - 2

3. (a) Draw the projections of the following points on the same ground line, keeping the projectors 25mm apart.
 - (i) A, in the HP and 20mm behind the VP
 - (ii) B, 40mm above the HP and 25mm in front of the VP
 - (iii) C, in the VP and 40mm above the HP
 (b) A line CD is parallel to VP and inclined at 40° to HP. C is in HP and 25mm in front of VP. Top view is 50mm long. Find its true length. [8+8]

4. A line PQ 100mm long is inclined at 30° to the HP and at 45° to the VP. Its midpoint is in the VP and 20mm above the HP. Draw its projections, if its end P is in the third quadrant Q in the first quadrant. [16]

5. A hexagonal lamina of 20mm side rests on one of its corners on HP. The diagonal passing through this corner is inclined at 45° to HP. The lamina is then rotated through 90° such that the top view of this diagonal is perpendicular to VP and the surface is still inclined at 45° to HP. Draw the projections of the lamina. [16]

6. Draw the projections of a pentagonal prism, base 25mm side and axis 50mm long, resting on one of its rectangular faces on the ground, with the axis inclined at 45° to the VP. [16]

7. Draw the isometric view of Fig.2 [16]

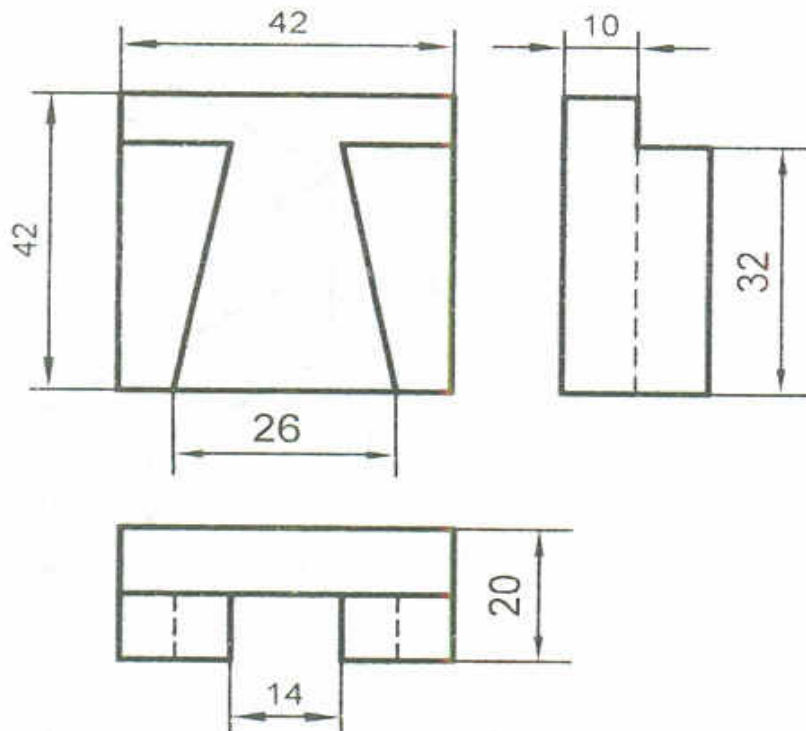

Fig.2



Subject Code: R13109/R13

Set No - 3

I B.Tech I Semester Regular/Supple. Examinations Nov./Dec. - 2015

ENGINEERING DRAWING

(Common to ECE, EIE, Bio-Tech, E Com.E, Agri.E)

Time: 3 hours

Max. Marks: 70

Question Paper Consists of **Part-A** and **Part-B**
 Answering the question in **Part-A** is Compulsory,
 Three Questions should be answered from **Part-B**

PART-A

1. (a) Draw the isometric view of Fig.1.

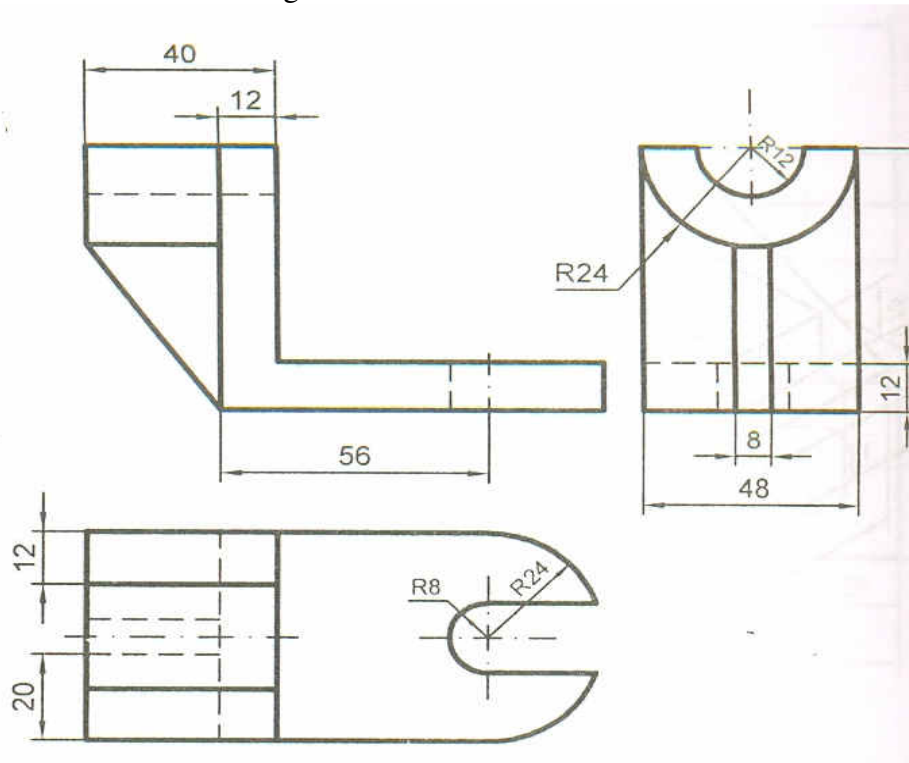

Fig.1

- (b) A thin 30° - 60° set square has its longest edge in VP and inclined at 30° to HP. Its surface makes 45° with VP. Draw its projections.

[12+10]

PART-B

2. (a) The area of a field is 50,000 sq.m. The length and the breadth of the field, on the map is 10cm and 8cm respectively. Construct a diagonal scale which can read up to one meter. Mark the length of 235 meter on the scale. What is the RF of the scale?
 (b) A plot of ground is in the shape of a rectangle 110m x 50m. Inscribe an elliptical lawn in it. Take a suitable scale.

[8+8]

3. (a) A point 30mm above xy line is the top view of two points P and Q. The elevation of P is 45mm above the HP while that of the point Q is 35mm below the HP Draw the projections of the points and states their position with reference to the principle planes and the quadrant in which they lie.



Subject Code: R13109/R13

Set No - 3

3. (b) A line EF 60mm long is in VP and inclined to HP. The top view measures 45mm. The end E is 15mm above HP. Draw the projections of the line. Find its inclination with HP. [8+8]
4. A line AB, 65mm long, has its end A 20mm above the HP and 25mm in front of the VP. The end B is 40mm above the HP and 65mm in front of the VP. Draw the projections of AB and show its inclinations with the HP and the VP. [16]
5. A circular lamina of 60mm diameter rests on HP on a point 1 on the circumference. The lamina is inclined to HP such that the top view of it is an ellipse of minor axis 35mm. The top view of the diameter through the point 1 makes an angle of 45° with VP. (i) Draw the projections (ii) Determine the angle made by the lamina with HP. [16]
6. A hexagonal pyramid, base 25mm side and axis 50mm long, has an edge of its base on the ground. Its axis is inclined at 30° to the ground and parallel to the VP. Draw its projections. [16]
7. Draw Fig.2 (a) Front View (b) Top View (c) Side View [16]

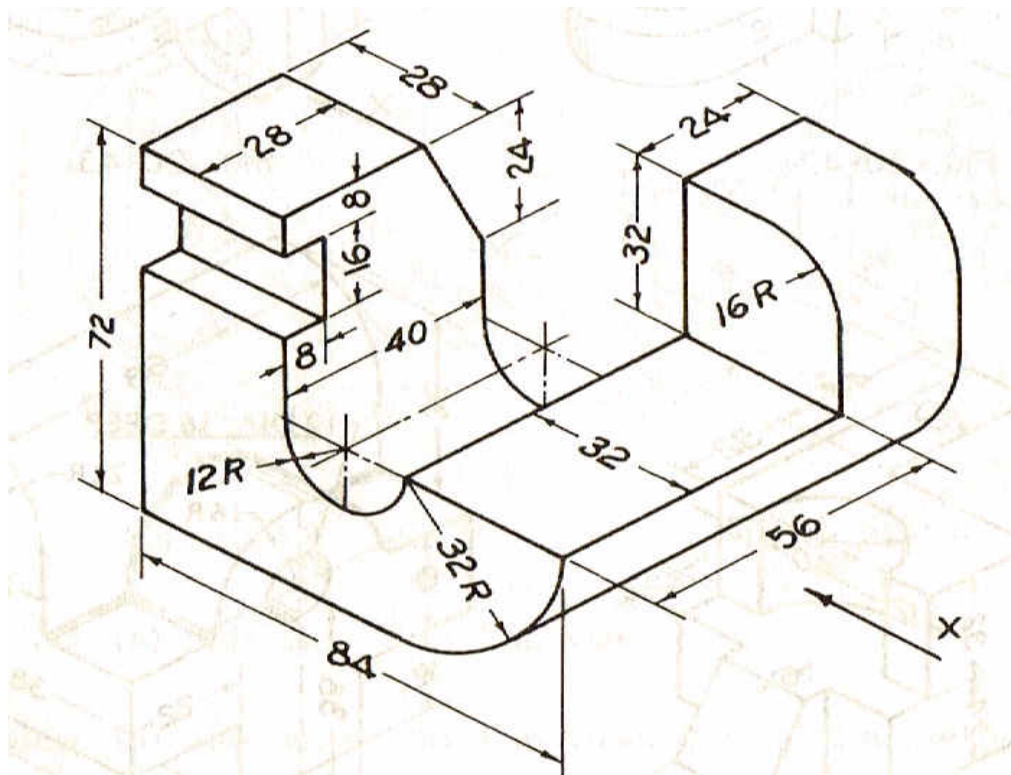

Fig.2

[16]



Subject Code: R13109/R13

Set No - 4

I B.Tech I Semester Regular/Supple. Examinations Nov./Dec. - 2015

ENGINEERING DRAWING

(Common to ECE, EIE, Bio-Tech, E Com.E, Agri.E)

Time: 3 hours

Max. Marks: 70

Question Paper Consists of **Part-A** and **Part-B**
 Answering the question in **Part-A** is Compulsory,
 Three Questions should be answered from **Part-B**

PART-A

1. (a) Draw Fig.1 (i) Front View (ii) Top View (iii) Side View

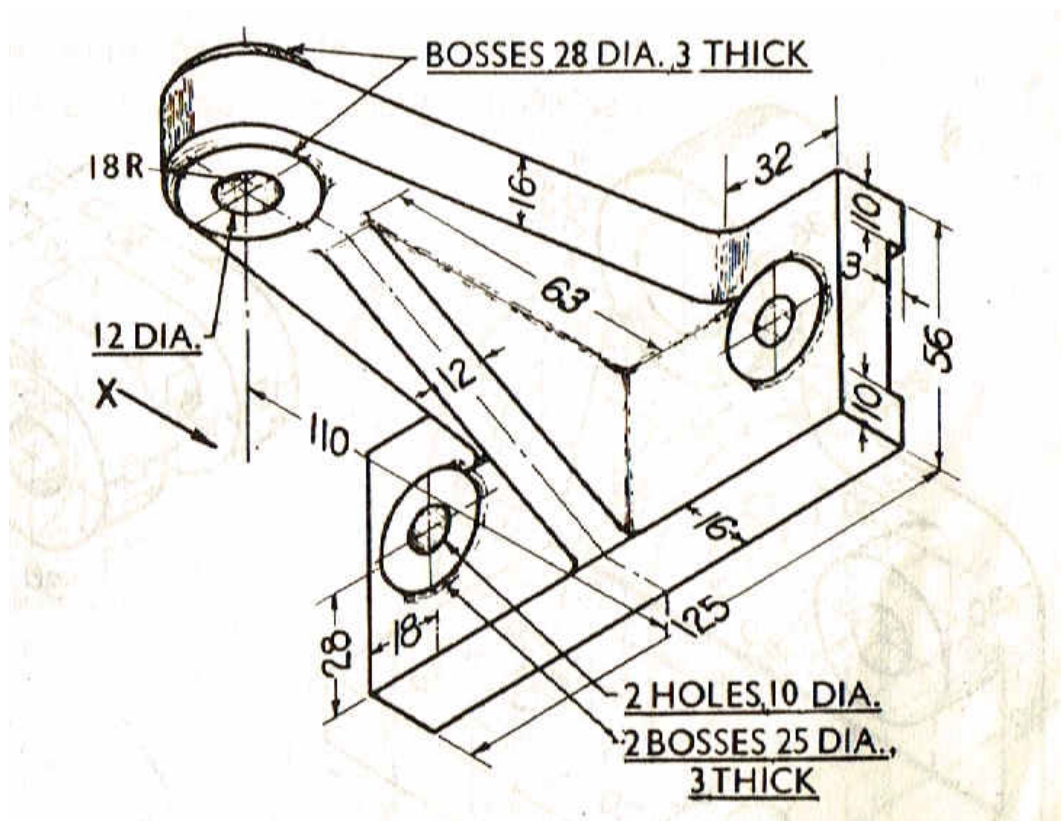

Fig.1

- (b) A regular hexagonal lamina of 26mm side has a central hole of 30mm diameter. Draw the front and top views when the surface of the lamina is inclined at 45° to HP. A side of lamina is inclined at 35° to VP.

[12+10]

PART-B

2. (a) The actual length of 500m is represented by a line of 15cm on a drawing. Construct a vernier scale to read up to 600m. Mark on the scale a length of 549m.
 (b) Construct a regular polygon of any number of sides, given the length of its sides equal to 25mm.

[8+8]



Subject Code: R13109/R13

Set No - 4

3. (a) A line GH 45mm long is in HP and inclined to VP. The end G is 15mm in front of VP. Length of front view is 35mm. Draw the projections of the line. Determine its inclination with VP.
 (b) A point A is situated in the first quadrant. Its shortest distance from the intersection point of HP; VP and auxiliary plane is 60mm and it is equidistance from the principle planes. Draw the projections of the point and determine its distance from the principle planes. [8+8]
4. A line AB, 90mm long, is inclined at 45° to the HP and its top view makes an angle of 60° with the VP. The end A is in the HP and 12mm in front of the VP. Draw its front view and find its true inclination with the VP. [16]
5. A semi-circular lamina of 64mm diameter has its straight edge in VP and inclined at an angle of 45° to HP. The surface of the lamina makes an angle of 30° with VP. Draw the projections. [16]
6. Draw the projections of a cone, base 75mm diameter and axis 100mm long, lying on the ground on one of its generators with the axis parallel to the VP. [16]
7. Draw the isometric view of Fig.2 [16]

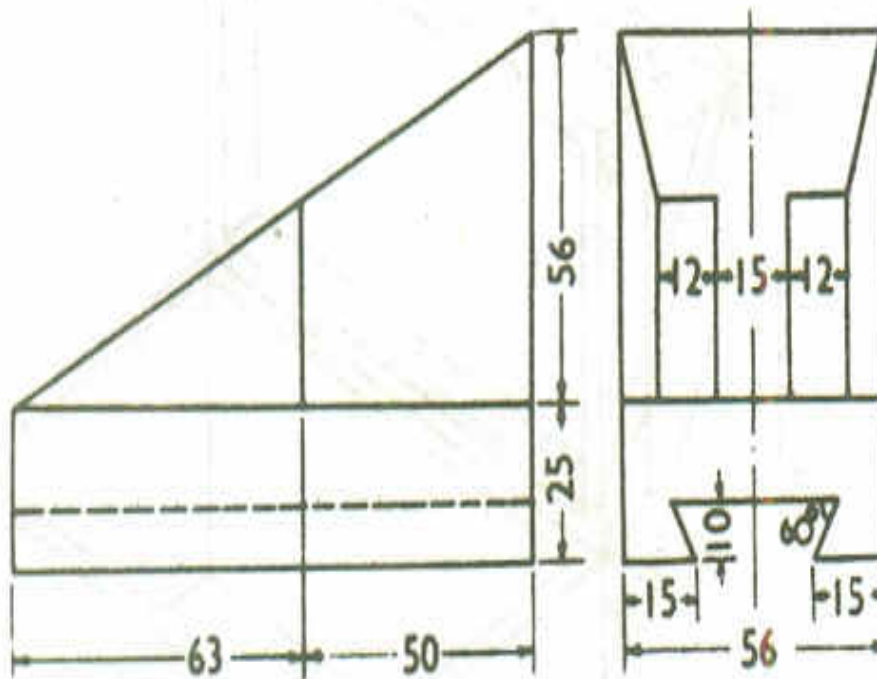

Fig.2

[16]

